

CKFD03 FORD ZETEC



Kit di corpi farfallati doppi per motori Ford Zetec 1,8 e 2,0 comprensivo di 2 corpi farfallati TB45, collettore di aspirazione, flauto benzina, e 4 trombette lunghe 90 mm. Questo kit e' stato progettato e realizzato per massimizzare il rendimento dei motori Ford Zetec utilizzati su vetture Westfield, Morgan, Ford Mondeo, Fiesta, Escort e molte altre, per competizioni Rally e gare in circuito.



Ford Zetec ITB throttle body kit from Jenvey Dynamics includes a pair of TB45 throttle bodies (ITB's), a Jenvey Dynamics EFI inlet manifold, fuel rail and four 90mm long airhorns. Jenvey throttle bodies and all Jenvey throttle body accessories are engineered for Motorsport, offering excellent performance, reliability, lightness and value. This kit is ideal for road, track or rally use. This kit is ideal for Kit cars, Race cars, Westfields, Morgans, Fiestas, Focus and Mondeos as well as several specials.

JENVEY

MF03 - Ford Zetec manifold for twin throttle bodies

© Jenvey Dynamics Ltd 2000-2010
Issue 2
www.jenvey.co.uk

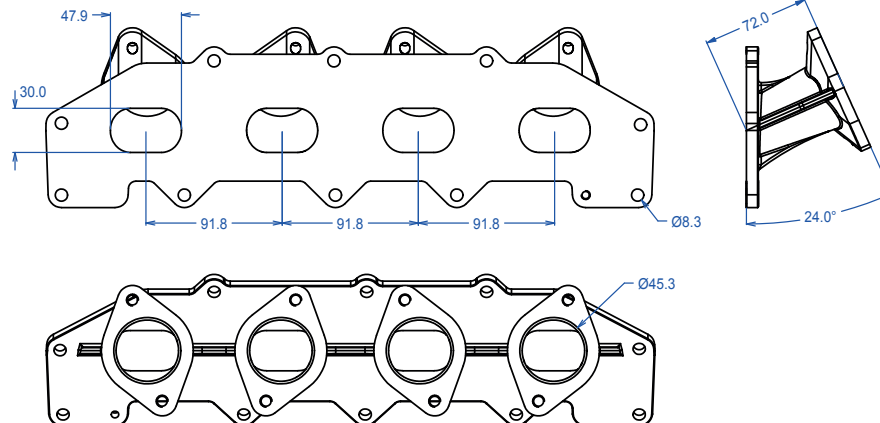

Flanges for Jenvey twin throttle bodies.
May be ported up to 50mm at body flange and proportionally at head flange.

