

CKFD12 FORD V6 DURATEC



Kit per applicazione di farfalle singole coniche su motori Ford Duratec V6 3000 cc, composto di 6 corpi farfallati SF45/0/1, collettore di aspirazione, flauto benzina, completo di leveraggi comando acceleratore per il V6 e 6 trombette lunghe 90 mm. Utilizzato per elaborazioni di tipo kit car, è stato progettato per uso competizioni, ma adattabile in tutti gli utilizzi, garantisce un'ottimizzazione dell'aspirazione e del riempimento della camera di combustione aumentando così la potenza del motore. Per motori 3000 cc derivati dalla Mondeo, il kit non monta sui piu' recenti motori 2500 cc.



Ford Duratec V6 ITB throttle body kit from Jenvey Dynamics includes six SF45/0/1 throttle bodies, cable linkage, EFI inlet manifolds and six 90mm long airhorns. Jenvey throttle bodies and all Jenvey throttle body accessories are engineered for Motorsport, offering excellent performance, reliability, lightness and value. This kit is ideal for road, track or rally use. This engine is from the 3.0 Litre Mondeo (this does not fit the earlier 2.5l engine) and is used in many kit cars and specials. Made to order - up to 2 weeks to dispatch.

JENVEY

MF12 - Ford Duratech V6 manifolds for individual throttle bodies

© Jenvey Dynamics Ltd 2000-2010
Issue 2
www.jenvey.co.uk

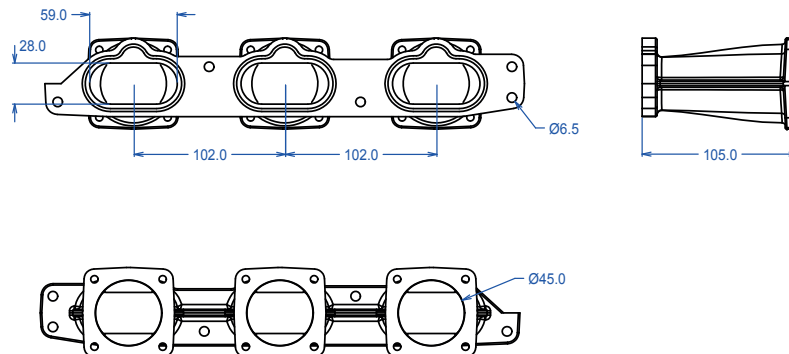

Flanges for Jenvey SF throttle bodies. May be ported up to 50mm at body flange and proportionally at head flange.
O ring seal to cylinder head.
Supplied as matched pair.

