

CKB01 BMW MINI



BMW Mini ITB kit corpo farfallato da Jenvey Dynamics comprende / 0/1 corpi farfallati quattro SF40, un collettore di aspirazione Jenvey Dynamics EFI, rail e quattro 40 millimetri lunghi airhorns. Corpi farfallati Jenvey e tutti gli accessori per il corpo farfallato Jenvey sono progettati per Motorsport, che offre ottime prestazioni, l'affidabilità, la leggerezza e il valore. Questo kit è ideale per strada, pista o use. This raduno kit è per i primi motori piazza porting. Ordinazone - fino a 2 settimane per le spedizioni.



BMW Mini ITB throttle body kit from Jenvey Dynamics includes four SF40/0/1 throttle bodies, a Jenvey Dynamics EFI inlet manifold, fuel rail and four 40mm long airhorns. Jenvey throttle bodies and all Jenvey throttle body accessories are engineered for Motorsport, offering excellent performance, reliability, lightness and value. This kit is ideal for road, track or rally use. This kit is for the early square ported engine. Made to order - up to 2 weeks to dispatch.

JENVEY

MB01 - BMW Mini manifold for individual throttle bodies

© Jenvey Dynamics Ltd 2000-2010
Issue 2
www.jenvey.co.uk

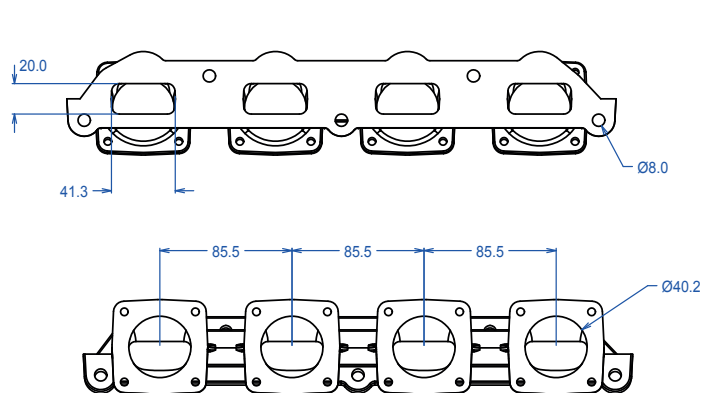

Flanges for Jenvey SF throttle bodies. May be ported up to 45mm at body flange and proportionally at head flange
Angled for under-bonnet clearance
Undrilled bosses on top side for idle air / vacuum take off / injectors / etc



Filtro aria profondo 40 mm / Foam element air filter - standard fitment - 40mm deep