

CKFD15 FORD DURATEC 2.5L



Kit di aspirazione singola adattabile sui motori Ford Duratec 2,5L composto di 2 corpi farfallati doppi 48TB, flauto benzina 4 trombette lunghe 90 mm. Utilizzato per elaborazioni di tipo kit car, e' stato progettato per uso competizioni, ma adattabile in tutti gli utilizzi dove e' richiesto un'aumento di potenza.



A Twin Body kit for the 2.5L Ford Duratec engine which contains; an inlet manifold - two 48mm TB throttle bodies - fuel rails and 90mm long airhorns. Ideal for track, road or rally. The Ford Duratec engine is used in several kit cars, Rally Cars and OE Applications.

JENVEY

MF16 - Ford 2.5L Duratec manifold for twin throttle bodies

© Jenvey Dynamics Ltd 2009-2014
Issue 2
www.jenvey.co.uk

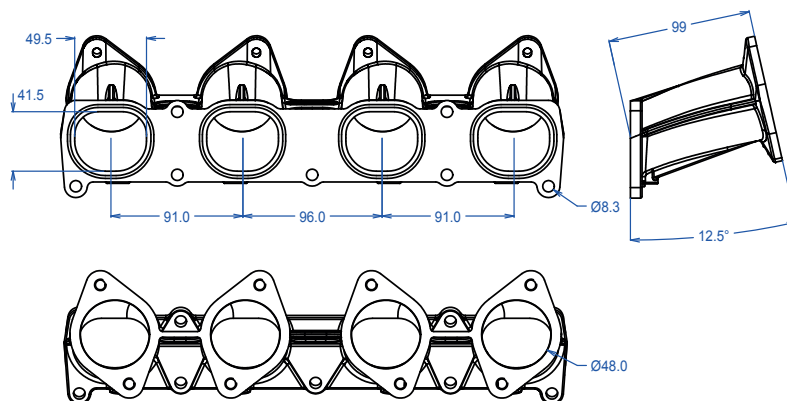

Flanges for Jenvey TB throttle bodies. May be ported up to 52mm.
O ring seal to cylinder head
Additional material to allow matching to ported cylinder heads
Undrilled bosses on underside for idle air / vacuum take off / etc

A GRP moulded base plate. Designed to clear the fuel rails on SF ST and TH style bodies. Use with a Jenvey filter or airbox. Supplied blank. see ABB2/M for machining



Filtro aria profondo 65 mm / Foam element air filter - standard fitment - 65 mm deep