

CKHA03 HONDA B16 E B18 C5



Kit per applicazione di farfalle doppie diametro 45 mm su motori Honda B16 & B18c5 composto di 2 corpi farfallati doppi TB45, collettore di aspirazione, flauto benzina, leveraggi completi, e di trombette lunghe 90 mm. Utilizzato per elaborazioni di tipo kit car, è stato progettato per uso competizioni, ma adattabile in tutti gli utilizzi, garantisce un'ottimizzazione dell'aspirazione e del riempimento della camera di combustione aumentando così la potenza del motore. Per motori Honda installati su svariate vetture come Civic e Prelude.



Honda B16 & B18C5 ITB throttle body kit from Jenvey Dynamics includes a pair of TB45 throttle bodies (ITB's), a Jenvey Dynamics EFI inlet manifold, fuel rail and four 90mm long airhorns. Jenvey throttle bodies and all Jenvey throttle body accessories are engineered for Motorsport, offering excellent performance, reliability, lightness and value. This kit is ideal for road, track or rally use. This kit is ideal for a wide range of Honda's including the Civic and Prelude. Up to 2 weeks to dispatch.

JENVEY

MH06 - Honda B16 and B18 C5 manifold for twin throttle bodies

© Jenvey Dynamics Ltd 2000-2010
Issue 2
www.jenvey.co.uk

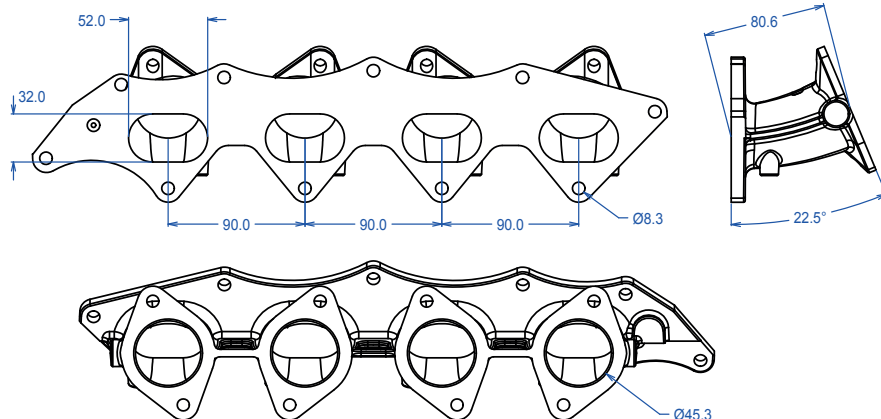

May be ported out to 48mm.
Undrilled bosses on underside for vacuum tappings.
Water tapping boss with drill starter point.

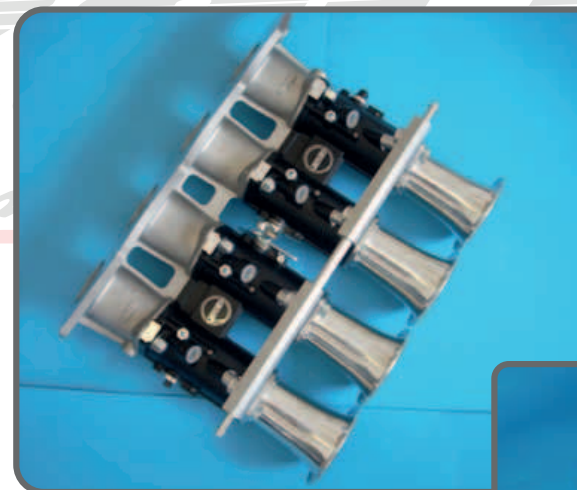

Filtro aria profondo 65 mm / Foam element air filter - standard fitment - 65 mm deep