

CKHA02 HONDA B18 C1EC4



Kit per applicazione di farfalle singole coniche su motori Honda B18C1 & C4 composto di 4 corpi farfallati SF48/4,5/1, collettore di aspirazione, flauto benzina, leveraggi completi e di trombette lunghe 90 mm. Utilizzato per elaborazioni di tipo kit car, è stato progettato per uso competizioni, ma adattabile in tutti gli utilizzi, garantisce un'ottimizzazione dell'aspirazione e del riempimento della camera di combustione aumentando così la potenza del motore. Per motori Honda installati su svariate vetture come Civic e Prelude.



Honda B18C1 & C4 ITB throttle body kit from Jenvey Dynamics includes four SF48/4.5/1 taper throttle bodies (ITB's), a Jenvey Dynamics EFI inlet manifold, fuel rail and four 90mm long airhorns. Jenvey throttle bodies and all Jenvey throttle body accessories are engineered for Motorsport, offering excellent performance, reliability, lightness and value. This kit is ideal for road, track or rally use. This kit is ideal for a wide range of Honda's including the Civic and Prelude. Up to 2 weeks to dispatch.

JENVEY

MH04 - Honda B18 C1 and C4 manifold for individual throttle bodies

© Jenvey Dynamics Ltd 2000-2010
Issue 2
www.jenvey.co.uk

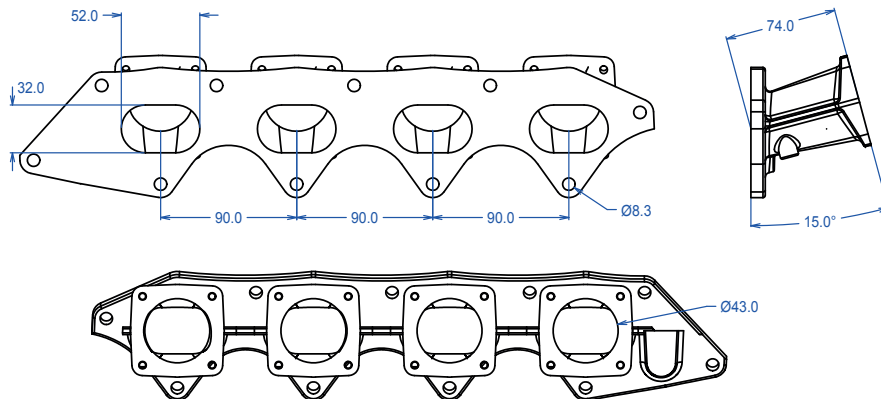

Flanges for Jenvey SF throttle bodies. May be ported out to 48mm.
Undrilled bosses on underside for vacuum tappings.

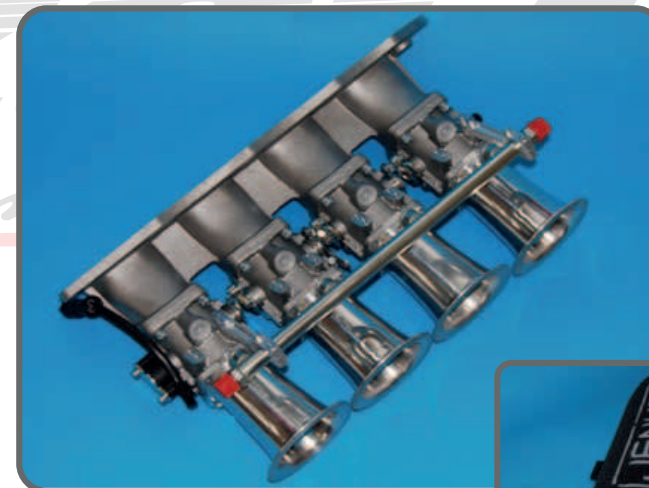

Filtro aria profondo 65 mm / Foam element air filter - standard fitment - 65 mm deep