

CKHA07 HONDA K20 EP3



Kit per applicazione di farfalle singole coniche su motori K20EP3 per motori da competizione, composto di 4 corpi farfallati SFD, collettore di aspirazione adattatore, flauto benzina, leveraggi completi e di trombette in carbonio. Utilizzato per elaborazioni di tipo kit car, è stato progettato per uso competizioni, ma adattabile in tutti gli utilizzi, garantisce un'ottimizzazione dell'aspirazione e del riempimento della camera di combustione aumentando così la potenza del motore. Per motori Honda K20EP3 installati su svariate vetture come Civic Type R. L'installazione del kit, richiede la modifica della posizione della pompa dell'acqua e la sostituzione degli iniettori originali.



Honda K20 EP3 ITB throttle body kit from Jenvey Dynamics includes four SF51/4.5/1 taper throttle bodies (ITB's), a Jenvey Dynamics EFI inlet manifold, fuel rail and four 90mm long airhorns. Jenvey throttle bodies and all Jenvey throttle body accessories are engineered for Motorsport, offering excellent performance, reliability, lightness and value. This kit is ideal for road, track or rally use. This kit is ideal for the Honda K20 EP3 shape cars like the Civic Type R. Modification of the water pump housing is required and the standard Honda injectors will need replacing with Bosch or Pico style. Made to order up to 2 weeks to dispatch.

JENVEY

MH07 - Honda K20 manifold for individual throttle bodies

© Jenvey Dynamics Ltd 2000-2010
Issue 2
www.jenvey.co.uk

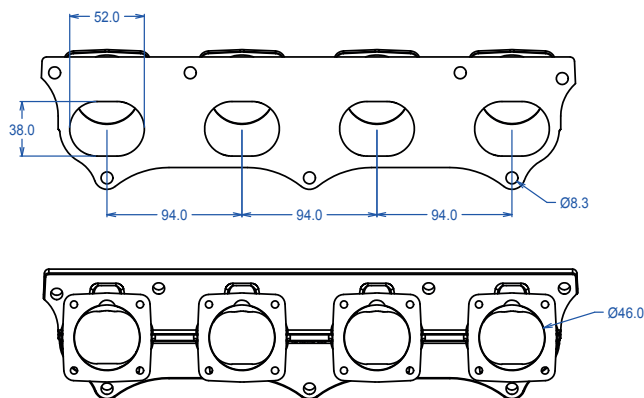

May be ported out to 52mm at body flange and proportionally at head flange.
Undrilled bosses on top side for injector ports, vacuum tappings etc.
Undrilled bosses on underside for vacuum tappings.

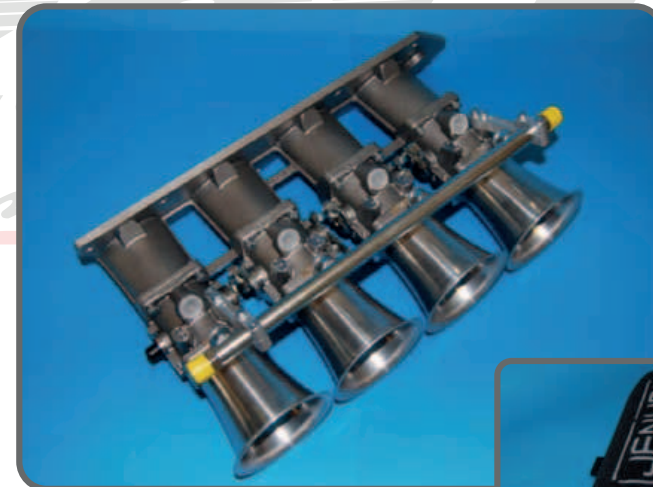

Filtro aria profondo 65 mm / Foam element air filter - standard fitment - 65 mm deep