

CKHA08 HONDA K20 FD2



Kit per applicazione di farfalle singole coniche su motori K20FD2 composto di 4 corpi farfallati SF51/4,5/1, collettore di aspirazione, flauto benzina, leveraggi completi e di trombette lunghe 90 mm. Utilizzato per elaborazioni di tipo kit car, e' stato progettato per uso competizioni, ma adattabile in tutti gli utilizzi, garantisce un'ottimizzazione dell'aspirazione e del riempimento della camera di combustione aumentando cosi' la potenza del motore. Per motori Honda K20FD2 installati su svariate vetture ultima versione CIVIC Type R utilizzata in Giappone ed in Europa omologata da Mugen. L'installazione del kit, richiede la modifica della posizione della pompa dell'acqua e la sostituzione degli iniettori originali con altri Bosch o simili tipo Pico.



Honda K20 FD2 ITB throttle body kit from Jenvey Dynamics includes four SF51/4.5/1 taper throttle bodies (ITB's), a Jenvey Dynamics EFI inlet manifold, fuel rail and four 90mm long airhorns. Jenvey throttle bodies and all Jenvey throttle body accessories are engineered for Motorsport, offering excellent performance, reliability, lightness and value. This kit is ideal for road, track or rally use. This engine is the new version used in the Japan Spec Civic Type R and homologated in Europe by Mugen. Modification of the water pump housing is required and the standard Honda injectors will need replacing with Bosch or Pico style. Made to order up to 2 weeks to dispatch.

JENVEY

MH08 - Honda K20 FD2 manifold for individual throttle bodies

© Jenvey Dynamics Ltd 2000-2010
Issue 2
www.jenvey.co.uk

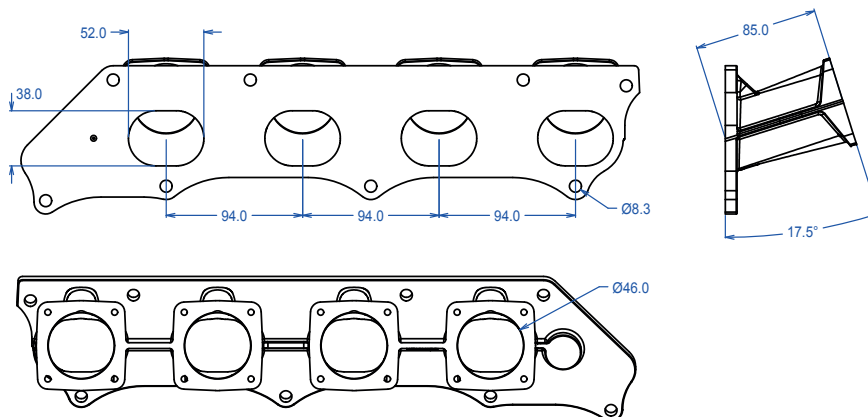

Flanges for Jenvey SF throttle bodies. May be ported out to 52mm at body flange and proportionally at head flange.
Undrilled bosses on top side for injector ports, vacuum tappings etc.
Undrilled bosses on underside for vacuum tappings.
Undrilled water tapping boss on head flange with drill starter point.



Filtro aria profondo 65 mm / Foam element air filter - standard fitment - 65 mm deep