

CKFD10 FORD 2L DURATEC



Kit per applicazione di farfalle singole coniche su motori Ford Duratec composto di 4 corpi farfallati SF51/4,5/1, collettore di aspirazione, flauto benzina e 4 trombette lunghe 90 mm. Utilizzato per elaborazioni di tipo kit car, e' stato progettato per uso competizioni, ma adattabile in tutti gli utilizzi, garantisce un'ottimizzazione dell'aspirazione e del riempimento della camera di combustione aumentando così la potenza del motore. Per motori Duratec su Westfields, Morgan, Fiesta, Focus e Mondeo.



Ford Duratec ITB throttle body kit from Jenvey Dynamics includes four SF51/4.5/1 taper throttle bodies (ITB's), a Jenvey Dynamics EFI inlet manifold, fuel rail and four 90mm long airhorns. Jenvey throttle bodies and all Jenvey throttle body accessories are engineered for Motorsport, offering excellent performance, reliability, lightness and value. This kit is ideal for road, track or rally use. This kit is ideal for Kit cars, Race cars, Westfields, Morgans, Fiestas, Focus's and Modeos as well as several specials. Up to 2 weeks to dispatch.

JENVEY

MF10 - Ford Duratec manifold for individual throttle bodies

© Jenvey Dynamics Ltd 2000-2010
Issue 1
www.jenvey.co.uk

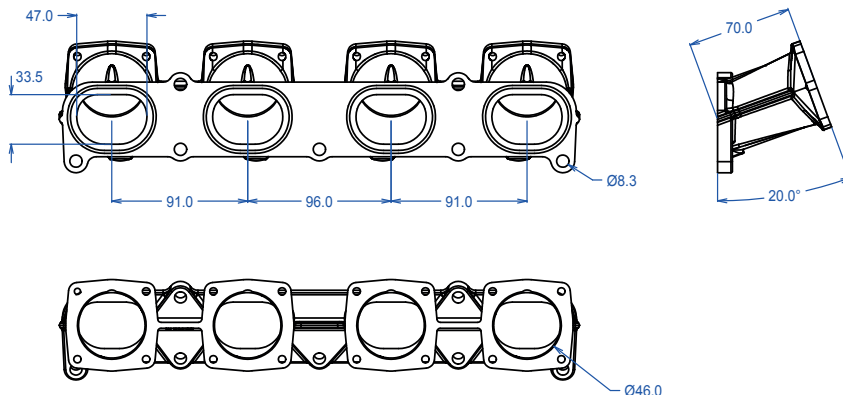

Flanges for Jenvey SF throttle bodies. May be ported up to 50mm.
O ring seal to cylinder head
Additional material to allow matching to ported cylinder heads
Undrilled bosses on underside for idle air / vacuum take off / etc

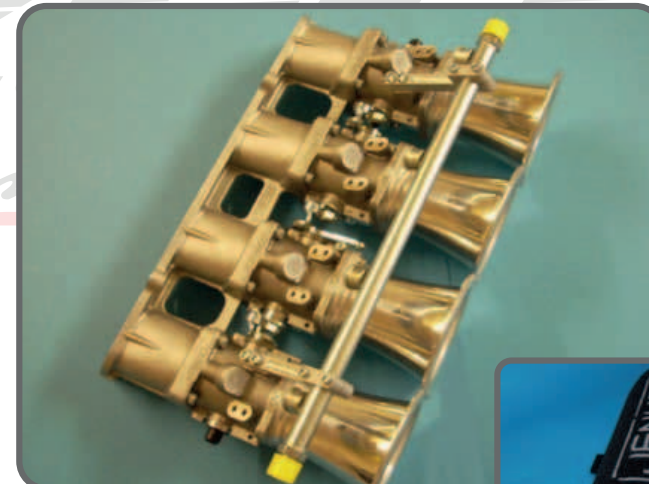

Filtro aria profondo 65 mm / Foam element air filter - standard fitment - 65 mm deep