

CKVRO1N ROVER K



Il kit corpi farfallati per Rover Serie K comprende quattro corpi farfallati singoli conici SF 48/4,5/1 un collettore di aspirazione, un flauto benzina e quattro trombette diametro 48 e lunghe 90 millimetri. I corpi farfallati Jenvey e tutti gli accessori, sono progettati per uso competizioni, offre ottime prestazioni, affidabilità, leggerezza e mantiene il suo valore nel tempo. Questo kit è adattabile sul motore Rover Serie K con cilindrata 1400/1600/1800 cc montati su Metro Rover, 200, Lotus Elise, Caterham e si può montare con alcune modifiche anche sui motori 2000 cc, questo kit è ideale per tutti i tipi di competizioni. Si consiglia di adattare i condotti della testata. Tempo di consegna 2 settimane.



Rover K series ITB throttle body kit from Jenvey Dynamics includes four SF48/4.5/1 taper throttle bodies (ITB's), a Jenvey Dynamics EFI inlet manifold, fuel rail and four 90mm long airhorns. Jenvey throttle bodies and all Jenvey throttle body accessories are engineered for Motorsport, offering excellent performance, reliability, lightness and value. This kit is ideal for road, track or rally use. This kit is for the 1.4, 1.6 and 1.8 Engines as well as the modified 2.0l engines. These engines can be found in Rover Metro, 200, Lotus Elise, Caterham and many kit cars Up to 2 weeks to dispatch.

JENVEY

MR08N - Rover K manifold for individual throttle bodies

© Jenvey Dynamics Ltd 2000-2010
Issue 2
www.jenvey.co.uk

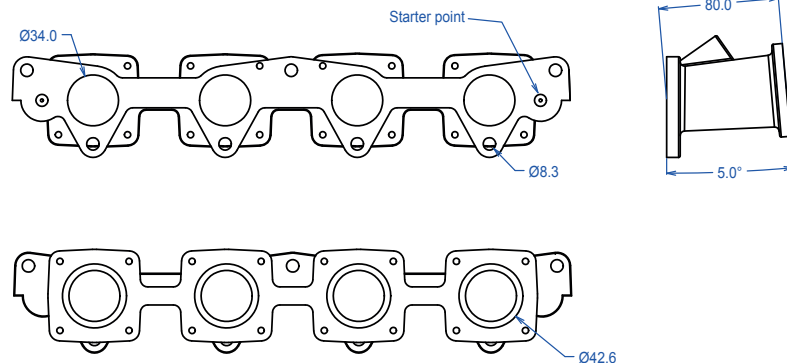

Flanges for Jenvey SF throttle bodies. May be ported out to 46mm at body flange and proportionally at head flange.
Undrilled bosses on top side for injectors or brakes, fast idle valve, sensors etc.
Option MR08 for drilled injector pockets.

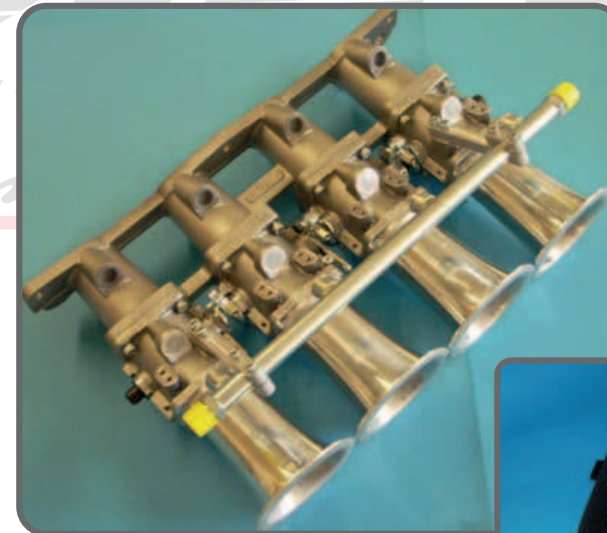

Filtro aria profondo 65 mm / Foam element air filter - standard fitment - 65 mm deep

